



**GLOBAL**  
FIRE EQUIPMENT

**Junior  
Mini-Rep**

**INSTALLATION  
MANUAL**



The Junior Mini-Rep is a fully functional mini version of the Juno-Net Repeater which can be used with any distributed or self contained Juno-Net or Junior based Fire Alarm system. Its reduced dimensions make it ideal for installation in reception areas or security booths where it would be impractical and unattractive to install a full size control panel. Like its big brother, the J-Net-Repeater, the Junior Mini-Rep permits full control of the system from multiple locations. Connection to the Juno-Net or Junior is via an RS422/RS485, Fibre Optic or TCP/IP interface. The Junior Mini-Rep is supplied complete with an RS422/RS485 interface as standard. Depending on control panel loading, power for the Junior Mini-Rep can be supplied from the control panel's auxiliary power output or an external 24 Volt power supply.

## Important Notes

- This equipment must only be installed and maintained by a suitably qualified and technically competent person.
- A basic knowledge and training in the installation of Fire Detection systems is assumed.
- The Fire Detection system should be designed by a suitably qualified person with reference to the Local Regulations and Guidance from the fire Officer where applicable.
- All wiring should be carried out with no power present in any part of the fire detection system.

**NOTE:** This unit should not be used to program the Juno Net panel as it does not provide total control over certain programming functions, namely all the functions that involve selecting loops in the range 2-96 as no switches for loop change are provided.

This document provides detailed information on how to install and operate the Junior Mini-Rep when used in conjunction with any of GFE's Analogue Addressable Fire Detection panels using GFE's RS-422/485 data loop interface (J-NET-INT-RS485-NEW).

Detailed information on how to install these units in a network using either Fiber Optics or TCP/IP interfaces is available in the appropriate interface installation manual and in the panel's installation manual.

This unit is compatible with all models of the following panels:

Junior V2, Junior V3, Junior V4, Juno Net and Juno Net En54

Please note that for Junior V2 and Juno Net (Classic) panels, certain functions associated with key-switch presses on the panel's front display are different than those represented on the Junior Mini-Rep. If the Junior Mini-Rep is going to be networked with either of these panel models, a modified overlay can optionally be provided in these occasions. Please contact GFE for details.

Optionally the Junior Mini-Rep can be provided with a key-switch in order to gain access to Access Level 2 ( Authorised User). Please contact GFE for details.

## INSTALLATION

In order to correctly install a Junior Mini-Rep the following steps should be taken:

- a) Remove the 4 screws fixing Junior Mini-Rep Display to the unit's back box.
- b) Disconnect flat cable interconnecting Junior Mini-Rep Main Board to Data Loop Interface. See Figure 3.
- c) Remove 3 fixing screws that hold the Junior Mini-Rep Data Loop Interface to back box. See Figure 1
- d) Fix unit's back box in required mounting position using the mounting holes provided. See Figure 1
- e) Re-mount Junior Mini-Rep Data Loop Interface on back box using the 3 screws previously removed.
- f) Reconnect flat cable connecting Junior Mini-Rep Main Board to Data Loop Interface board.
- g) Finally connect Power Supply. Junior Mini-Rep are supplied by an external 24V DC, normally derived from the control panel's auxiliary supply outputs. Do not apply supply voltage until installation is complete.
- h) Connect Data Loop Cables to interface following instructions provided in this manual and on appropriate data loop interface data sheet.

Please also refer to the panel's installation manual (Juno Net and Junior) for further details, in particular on how to integrate the Junior Mini-Rep on a networked system. All connections should be performed with all elements of the fire detection system unpowered.

This unit should be located where access to the internal components is not restricted and where the unit is not exposed to high levels of moisture, vibration and shock.

Any metal swarf could damage the PCBs if it is still present when the Repeater is powered up so it is recommended that all PCBs are removed from the box whilst the box is being installed. Make a note of the positions of the PCBs before removal.

**Warning** - observe ESD precautions when handling the PCBs.

All cables should be screened.

Data loop cable should be RS422/485 grade data cable, eg:

Signal cables for RS485 Communication Links (twisted pair) to Repeater panels

12 AWG Signal 88202 Belden 9583 WPW999

14 AWG Signal 88402 Belden 9581 WPW995

16 AWG Signal 88602 Belden 9575 WPW991

18 AWG Signal 88802 Belden 9574 WPW975

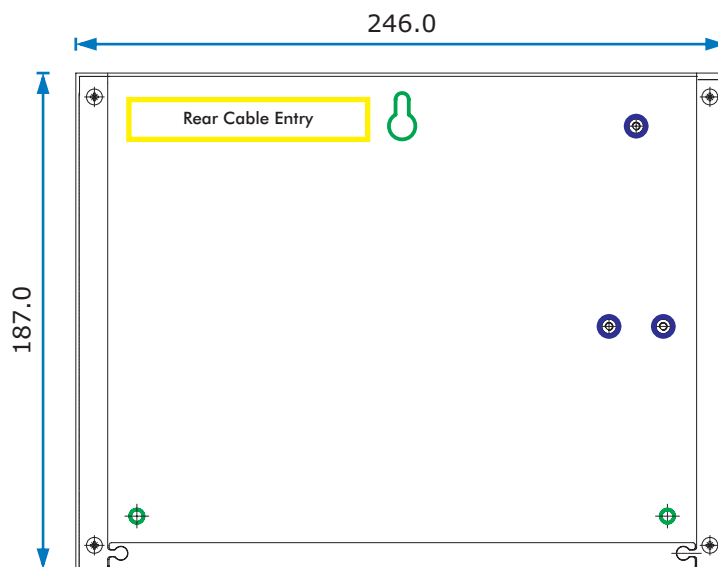
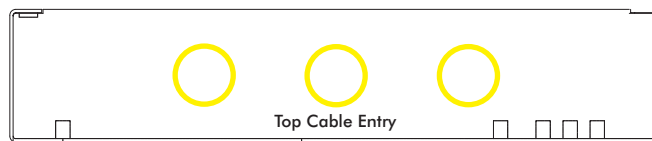
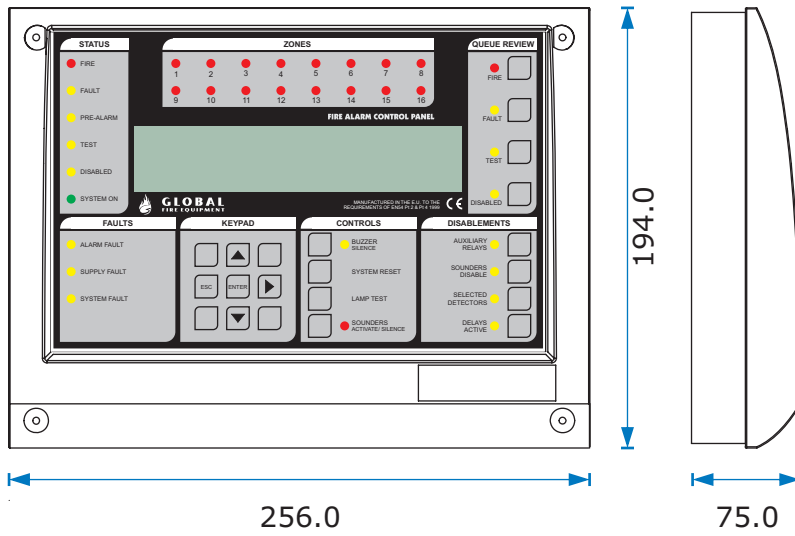
FIRETUF FDZ1000 by Draka 2 core

PIRELLI type FP200 Gold 2 core

PIRELLI type FP-PLUS

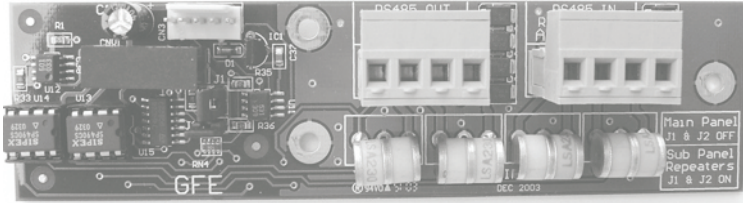
Fibre Optic: Multi.mode Dual Core sheathed fire proof with 62,5 $\mu$ /125 $\mu$  fibre terminated in ST connectors

All dimensions in mm

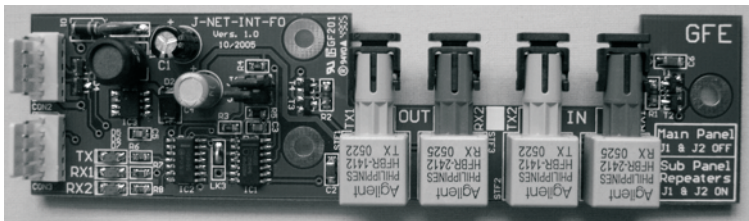


- Junior Mini-Rep Data Loop Interface PCB - Stand-offs
- Junior Mini-Rep Back Box - Mounting Holes

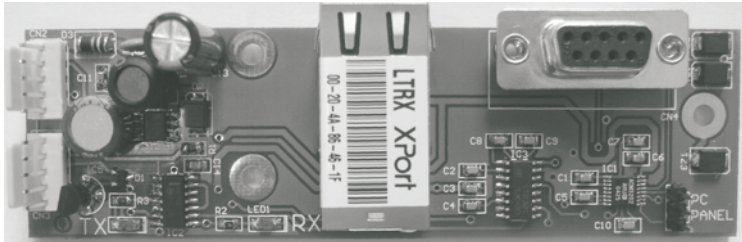
**Figure 1** Junior Mini-Rep - Mechanical Information



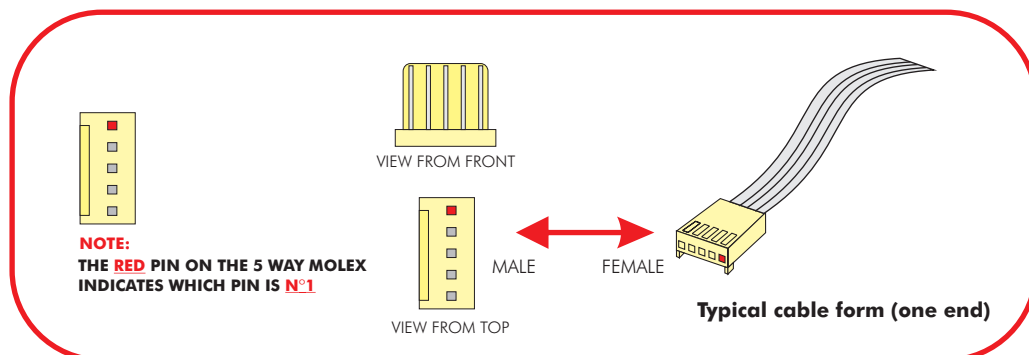
**J-NET-INT-485-NEW**  
**INTERFACE FOR RS485**  
**COMMUNICATION**



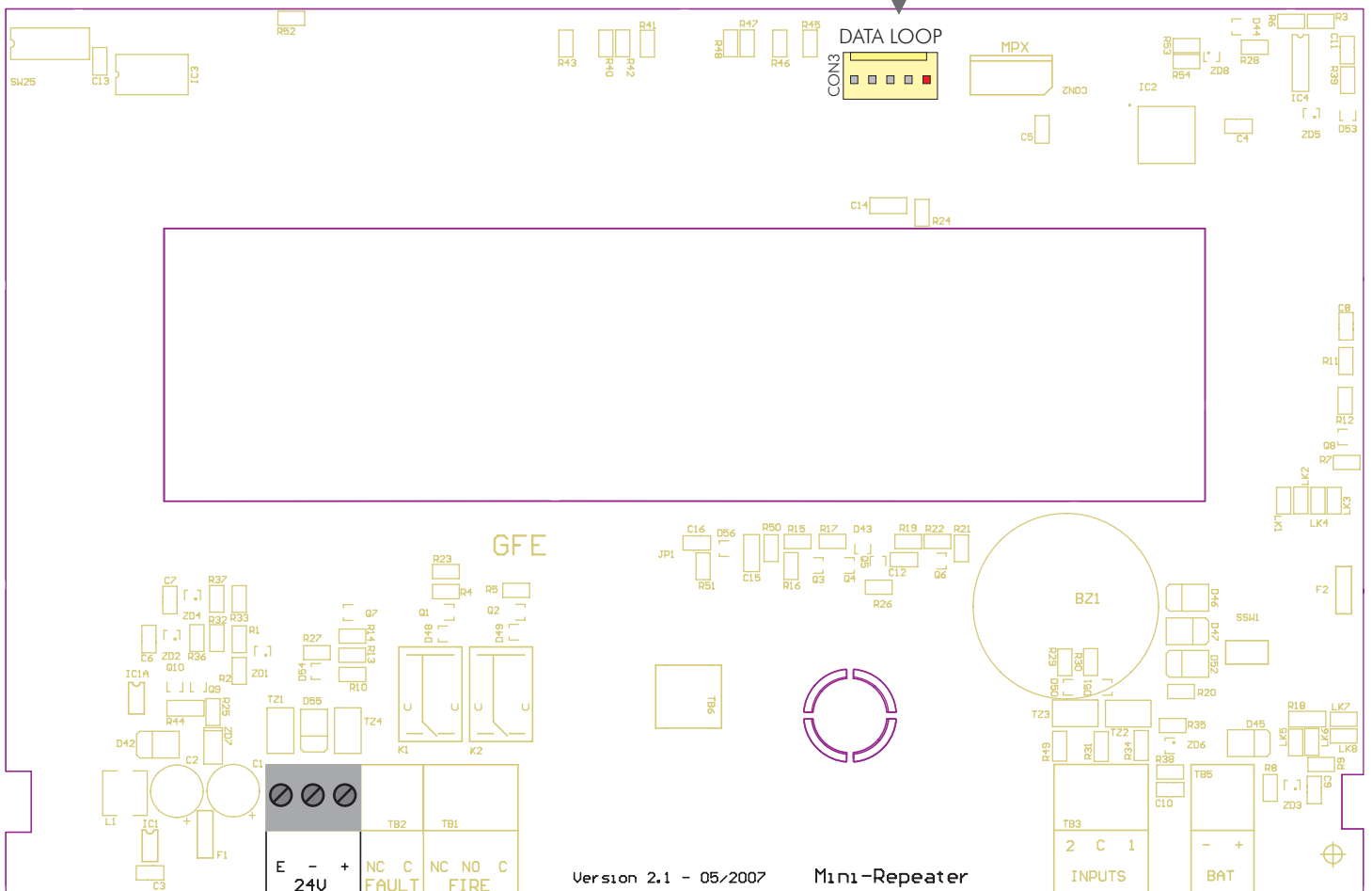
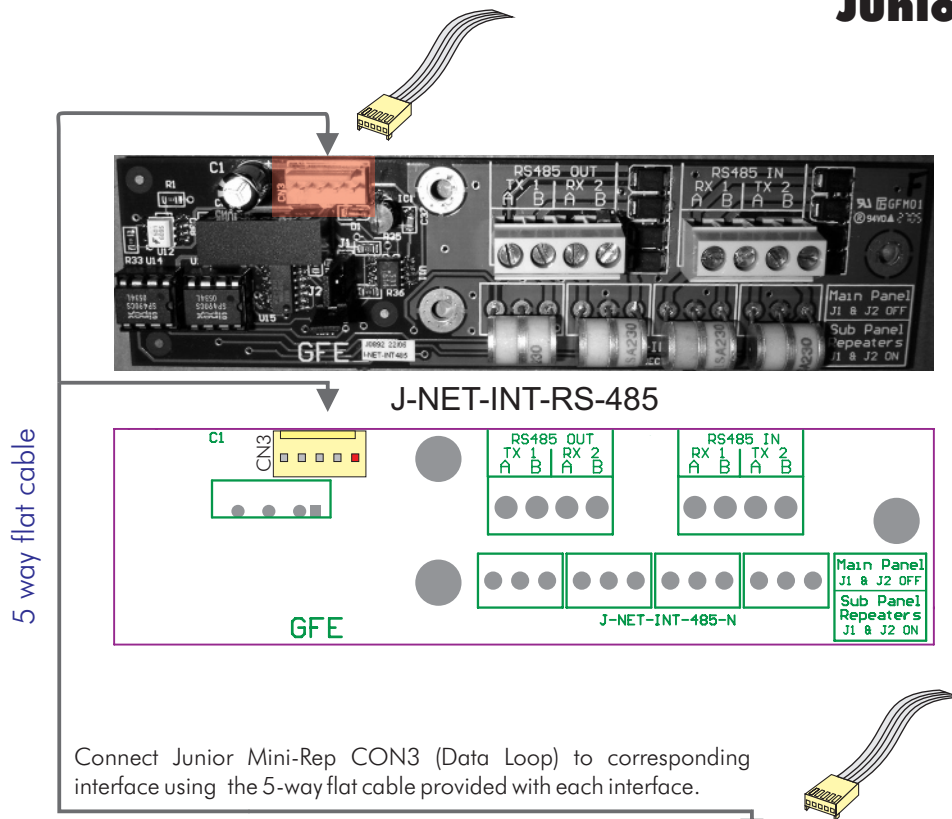
**J-NET-INT-FO:**  
**FIBRE OPTIC INTERFACE**



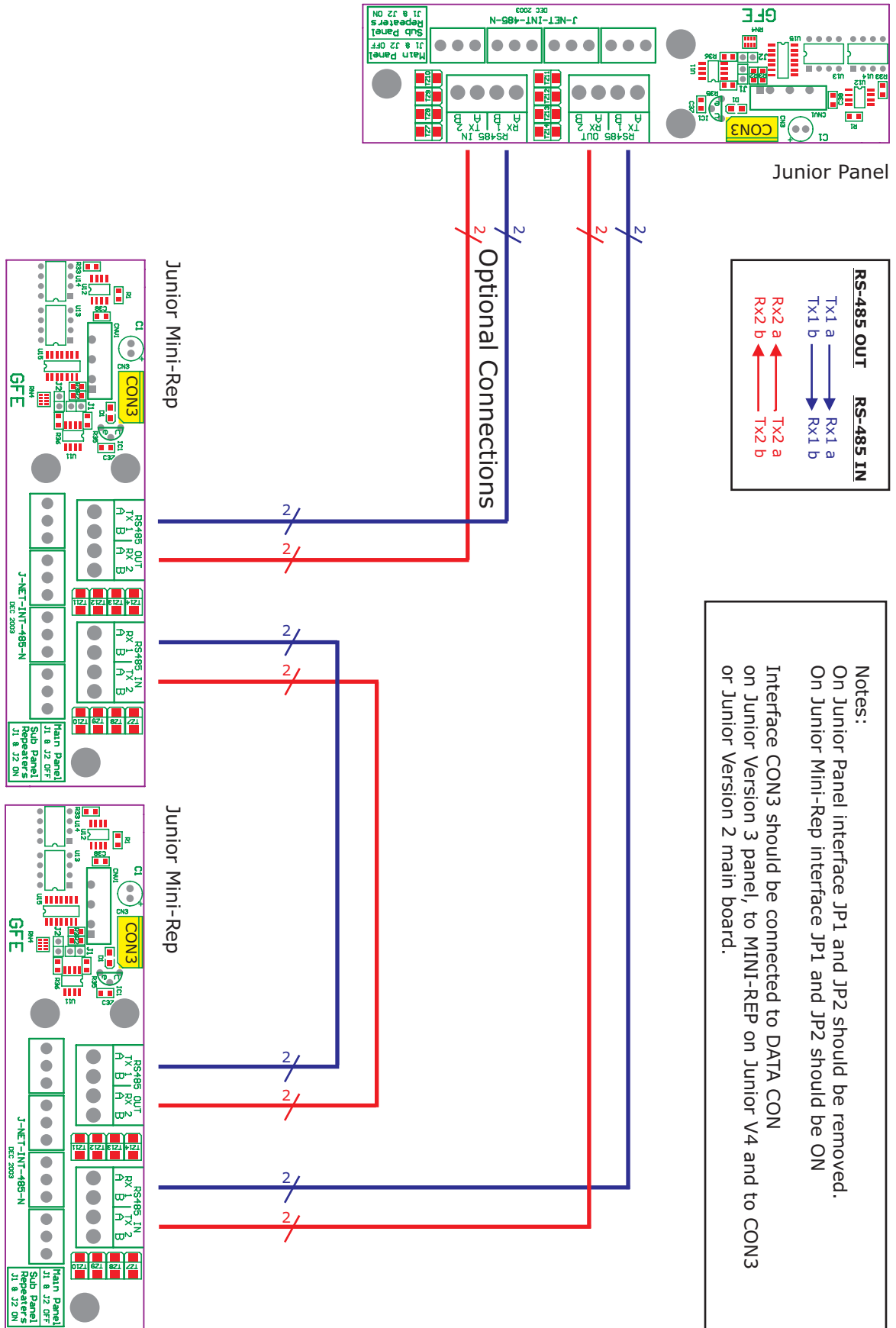
**J-NET-INT-TCP/IP**  
**INTERFACE FOR TCP/IP**  
**COMMUNICATION**



**Figure 2** Junior Mini-Rep - Network Interfaces



**Figure 3** Junior Mini-Rep - General Hardware and Connections Layout for RS-422/485 connection



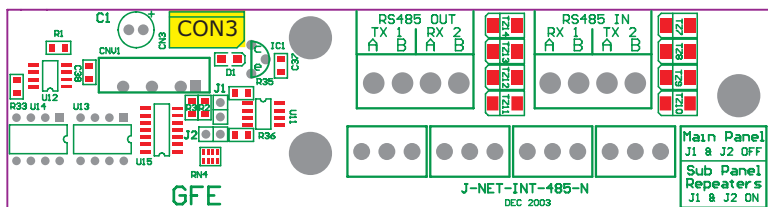
**Figure 4** Junior Panel Multi - Junior Mini-Rep - RS-485 Data Loop Connections



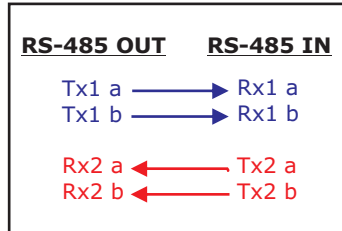
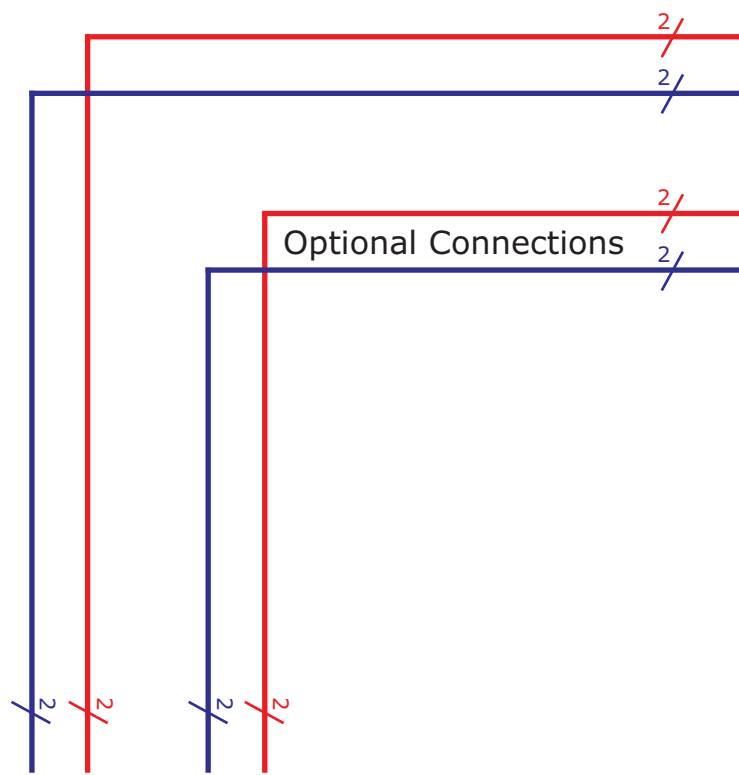
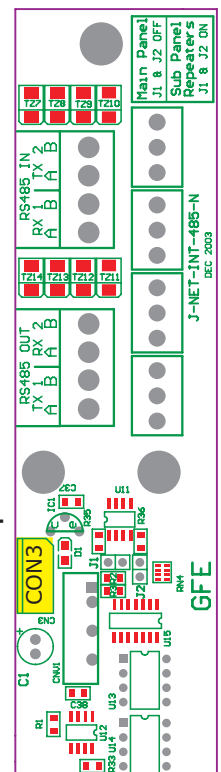
Notes:  
 On Junior Panel interface JP1 and JP2 should be removed.  
 On Junior Mini-Rep interface JP1 and JP2 should be ON

Interface CON3 should be connected to DATA CON on Junior Version 3 panel, to MINI-REP on Junior V4 and to CON3 or Junior Version 2 main board.

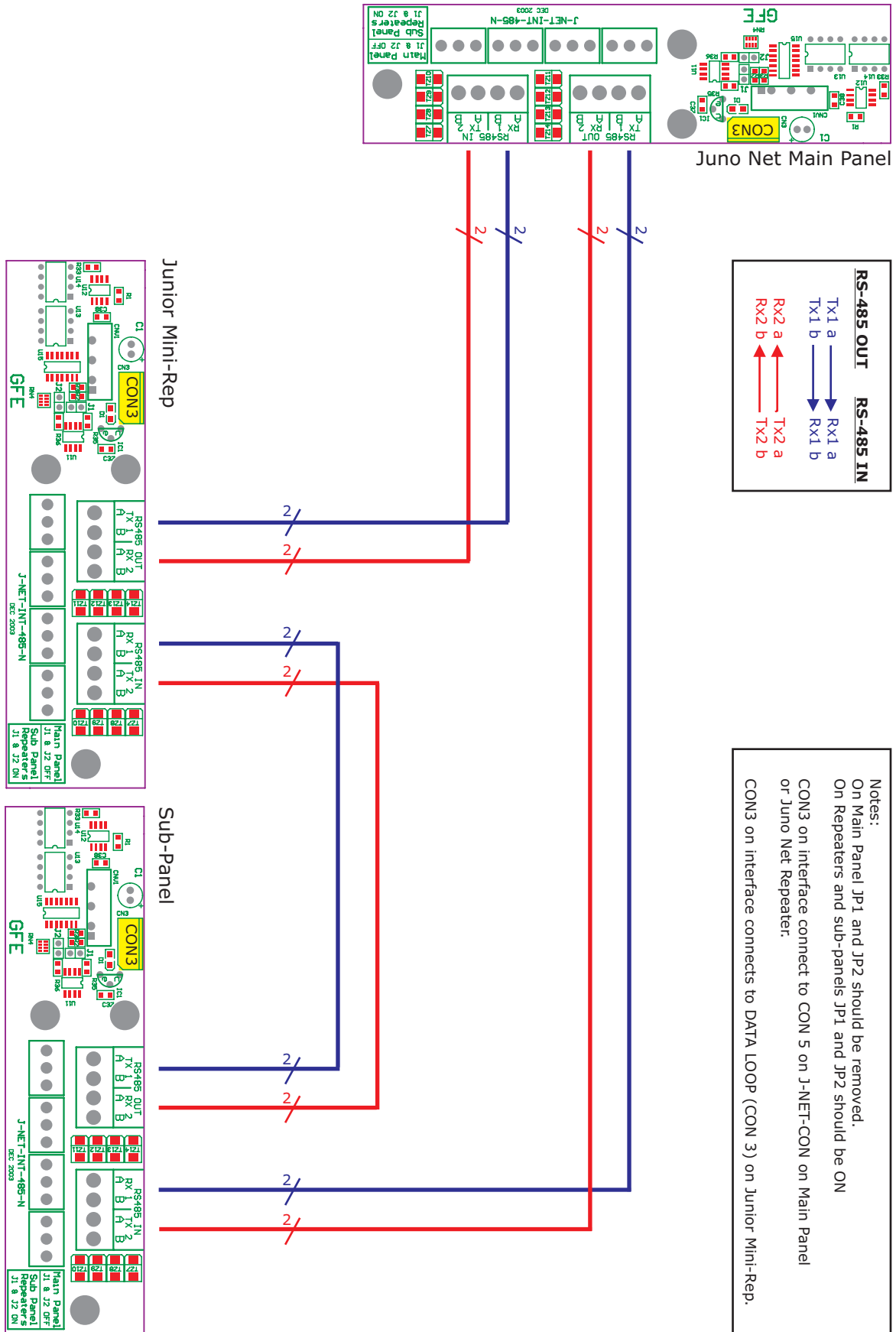
## Junior Panel



## Junior Mini-Rep

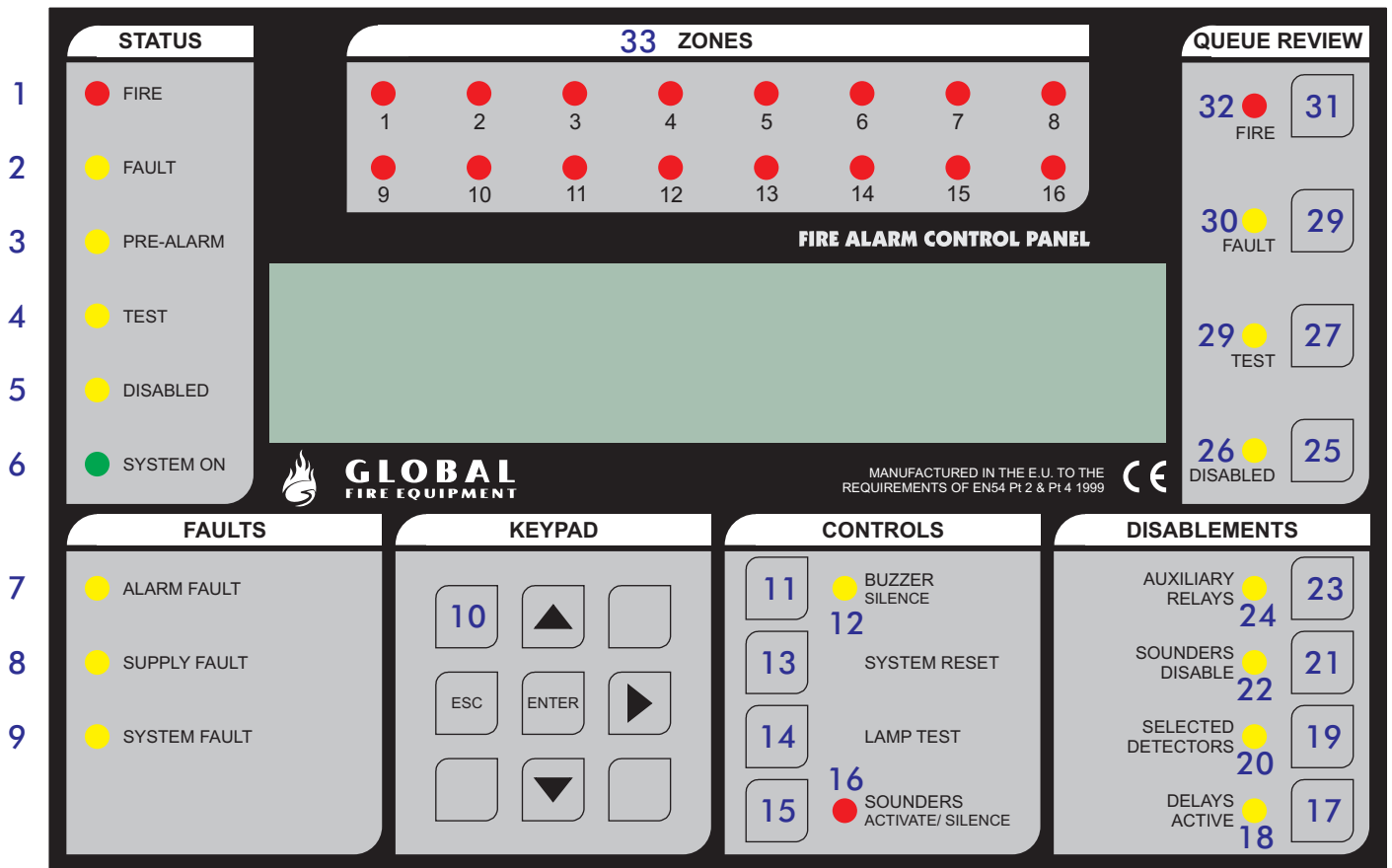


**Figure 5** Junior Panel Junior Mini-Rep (Single) - RS-485 Data Loop Connections



**Figure 6** Juno Net Panel - Junior Mini-Rep - Sub-Panel - RS-485 Data Loop Connections

## OPERATION



- 1 **FIRE:** If the LED is RED it indicates that there is a fire situation.
- 2 **FAULT:** If the LED is AMBER it indicates a fault situation. Additional information will be shown on the LCD display and, if applicable, on the LEDs in the FAULTS section of the main panel (i.e. 7, 8, 9, 10).
- 3 **PRE-ALARM:** If the LED is AMBER it indicates that a detector is in PRE-ALARM.
- 4 **TEST:** If the LED is AMBER it indicates that the panel is in a test mode.
- 5 **DISABLED:** If the LED is AMBER it indicates that at least one disablement exists.
- 6 **SYSTEM ON:** If the LED is GREEN it means that the panel is in ACTIVE mode. If the LED is flashing GREEN then the panel is in INSTALLATION mode.
- 7 **ALARM FAULT:** If the LED is AMBER it indicates that there is a problem with a loop sounder or conventional sounder circuit. This could be an open or short circuit.
- 8 **SUPPLY FAULT:** If the LED is AMBER it indicates that there is a Primary Supply (Electrical mains) Fault, a Battery Fault or that there is an Earth Fault.
- 9 **PROC. FAULT:** If the LED is AMBER it indicates that there is 5 Volt fault or a processor/program failure.
- 10 **KEYPAD:** Used to enter Authorized User code when available and gain access to all the functions associated with the key-switch presses. This only applies to Juno Net En54 and Junior V4 panels. Installer Code can also be entered and it will provide access to all the programming functions when this unit is networked to a Junior V4 panel but when unit is linked to Juno Net panel then only partial control over certain programming functions will be available.

## OPERATION (CONT.)

- 11 **BUZZER SILENCE:** Pressing this button will silence the internal buzzer during a new FIRE condition as well as during a new FAULT condition.
- 12 **BUZZER SILENCE:** If the LED is lit it indicates that a new FIRE or FAULT condition is present on the system.
- 13 **SYSTEM RESET:** Pressing this button restores the panel to its normal operating condition after an alarm. Alarms must be silenced before a SYSTEM RESET can be performed. A SYSTEM RESET does not clear any settings or disablements; it only clears FIRE and FAULT conditions (and then only if the source of the FIRE or FAULT has been cleared).
- 14 **LAMP TEST:** Whilst this button is depressed all of the repeater's LEDs will be illuminated and all of the LCD display pixels will be set to black. Use this button to confirm the LEDs and LCD display are functional.
- 15 **SOUNDERS (ACTIVATE/SILENCE):** Pressing this button will activate all sounders (main panel and Repeaters). Pressing the button again will silence the sounders.
- 16 **SOUNDERS (ACTIVATE/SILENCE):** If the LED is lit it means that all sounders are active.
- 17 **ACTIVE DELAYS :** Delays can be configured for the sounders and I/O modules using the programming functions. Pressing this button enables or disables these delays.
- 18 **ACTIVE DELAYS:** If the LED is AMBER it means that the delays are active.
- 19 **SELECTED DETECTORS:** Using the programming functions individual detectors can be set for SELECTIVE DISABLEMENT. When this button is activated those detectors will be disabled (isolated). Note that this button will only operate if at least one detector has been set for SELECTIVE DISABLEMENT.
- 20 **SELECTED DETECTORS:** If the LED is AMBER it means that the selected detectors are isolated.
- 21 **SOUNDERS DISABLE:** Pressing this button disables or enables the SOUNDERS on a SYSTEM.
- 22 **SOUNDERS DISABLE:** If the LED is lit it means that the SOUNDERS on the SYSTEM are disabled.
- 23 **AUXILIARY RELAYS:** Pressing this switch disables or enables all the relay and I/O module outputs.
- 24 **AUXILIARY RELAYS:** If the LED is lit it means that the relay and I/O module outputs are disabled.
- 25 **DISABLED:** If there are disablements then pressing this button will show the disablements on the LCD display. If there are more disablements than can be shown on the LCD display at one time then subsequent presses of this button will step through all the disablements.
- 26 **DISABLED:** If the LED is AMBER it means that there is at least one disablement.
- 27 **TEST:** If there are ZONES in test mode then pressing this button will show those ZONES on the LCD display. If more ZONES are in test mode than can be shown on the LCD display at one time then subsequent presses of the button will step through all the ZONES in test mode.
- 28 **TEST:** If the LED is AMBER it means that one or more ZONES are in test mode.
- 29 **FAULT:** If there is more than one FAULT, or if there is at least one FAULT and a FIRE, pressing this button will display the next FAULT report on the LCD display for 20 seconds. Subsequent presses will step through all the FAULT reports.
- 30 **FAULT:** If the LED is flashing AMBER it means that are FAULT reports to be reviewed. If the LED is steady AMBER then all FAULT reports have been reviewed.
- 31 **FIRE:** If there is more than one FIRE pressing this button will display the next FIRE report on the LCD display for 20 seconds. Subsequent presses will step through all the FIRE reports.
- 32 **FIRE:** If the LED is flashing RED it means that there are FIRE reports to be reviewed. If the LED is steady RED then all FIRE reports have been reviewed.
- 33 **ZONE FIRE INDICATION:** When RED led is lit for a particular zone it will indicate the presence of a FIRE condition in that zone. A separate LED is provided for each zone in the range from 1 to 16.

**NOTE: The functions of the switches, except for the LAMP TEST switch will only be operational after either the Authorized User ( Access Level 2) or the Programming Code ( Access Level 3) is entered. Please consult Panel's Installation and User Manual for further details.**

## TROUBLESHOOTING

### No LEDs are lit and the LCD shows no text messages.

- Verify if supply is properly connected to the unit.
- Verify using a voltmeter that the supply voltage is 24V DC.

### The green LED is ON but the LCD shows message “NO COMS TO MAIN PANEL”

This fault is normally associated with a communication fault between the Main Panel and Junior Mini-Rep(s). Press the SILENCE BUZZER button. The buzzer will stop and the AMBER led associated with this switch will be OFF.

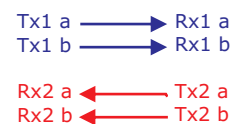
- Verify integrity of cables inter-connecting all data loop interfaces.
- Verify that interfaces are connected to their associated units in the right connector.
- Verify that jumpers JP1 and JP2 are placed on the interfaces associated with Repeaters and sub-panels and OFF on the Main Panel.

**Notes:**

On Main Panel interface JP1 and JP2 should be removed.  
On Junior Mini-Rep interface JP1 and JP2 should be ON

Interface CON3 should be connected to DATA LOOP on Junior Mini-Rep Main Board.

**RS-485 OUT      RS-485 IN**



Before conducting any verifications on the network wiring or connections between devices in the network, always remember to completely remove power across the network. The same applies when replacing any hardware parts on the fire detection system.

Always refer to the installation manuals for technical information.

Do not attempt any hardware repairs without the consent of GFE’s technical department.

If further technical information/ support is required, please contact GFE’s technical support department via e-mail [techs@globalfire.pt](mailto:techs@globalfire.pt) or direct line +351 289 896 565

Order Code	Junior MINI REP
Supply Voltage	28V DC nominal derived from panel’s Aux. Supply O/P
Supply Current	Typically 50 mA - 80 mA including RS-422/485 int. and LCD BL
Connections	+Supply, -Supply plus interface connections.
Repeater Network	RS-485, Fibre Optics, TCP/IP
Max. Humidity	4 units max. when powered from aux. supply o/p from panel
Operating Temperature	95% RH Non-Condensing
Dimensions	0 °C to 50 °C
Weight	256.0 (L) x 194.0 (W) x 75.0 (H) mm
	1.750 Kg

**Global Fire Equipment Lda.**

MARF - Armazens F3 e F4, Sítio do Guelhim, Estoi, 8009-021 FARO, PORTUGAL  
Tel: + 351 289 896 560 Fax: + 351 289 865 587



**Sales** sales@globalfire.pt **Technical Support** techs@globalfire.pt